

**TRUTH
CENTERED
TRANSFORMATION**

MODULE

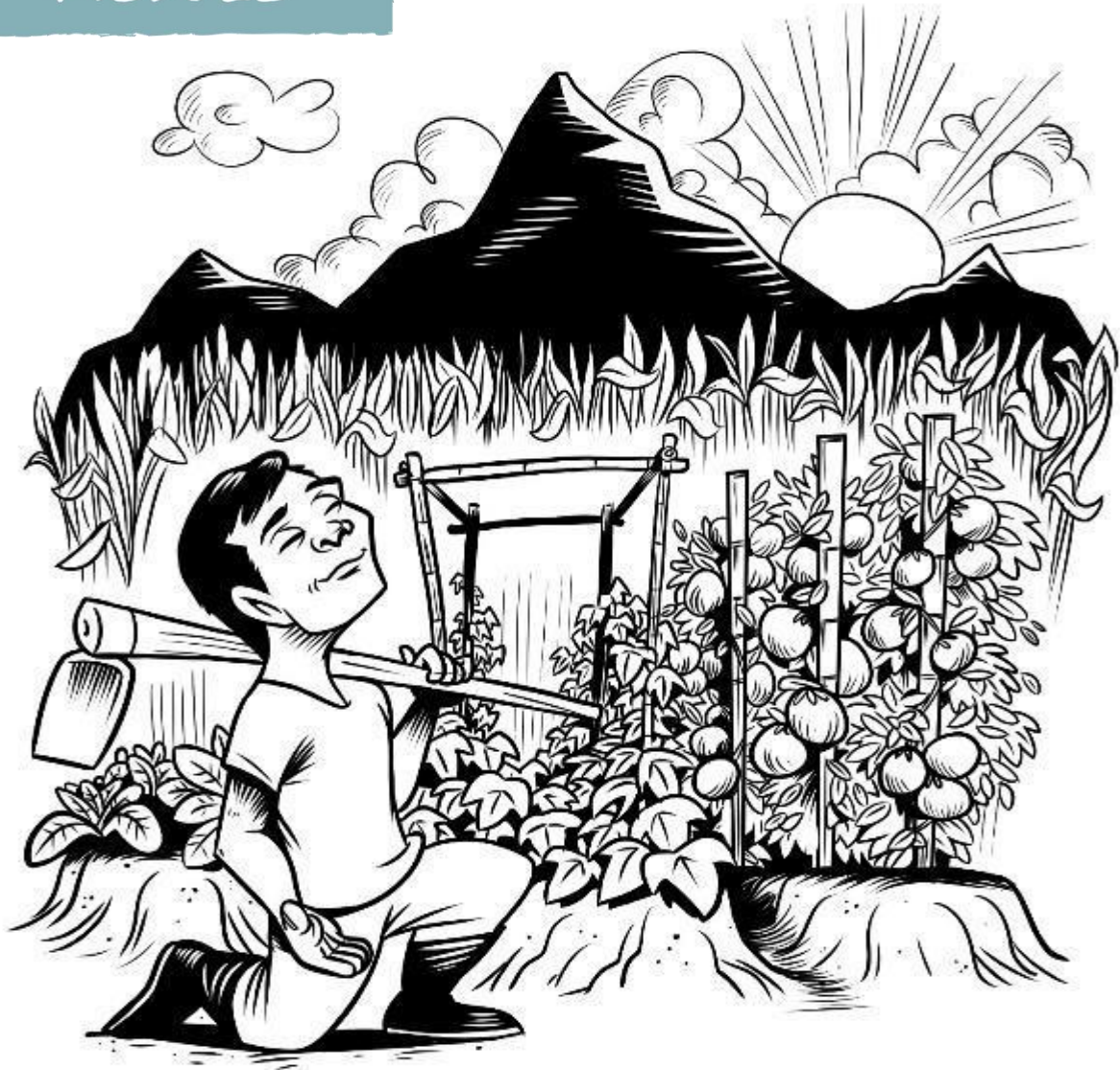

AGRICULTURE VISUAL AIDS

Contents

Lesson 2: People's Role in Creation

Who Rules Over Creation? Role Play – Print one copy. Explain each role to the volunteers before the lesson.

Creation Cards – Print 6 pages and cut each page in half for one set of 12 cards. Make at least 3 sets – one set for each group.

Lesson 5: Caring for Our Soil

What is in Soil? – Print one copy

Dibble Sticks – Print one copy

Narrow Slots or Strips using a Ripper – Print one copy

Small Planting Holes or Pits – Print one copy

Common Green Manure Cover Crops (GMCC) with Planting Instructions* – Print one copy

Lesson 6: Nutrients for Growing Plants

Nutrient Cycle – Print one copy

Nutrients by Stage Chart* – Print one copy

Nutrients & Stages Cards – Print one set per group

Adding Nutrients Cards – Print one set per group

Organic Materials for Each Stage of Growth – Print one copy

How to Make Your Own Fertiliser* – Print one copy

Lesson 7: All-Year Food Gardens

All-Year Food Garden – Print one copy

Ten Basic Steps to Make an All-Year Food Garden poster – Print one copy or create a large poster.

Steps for Making All-Year Food Garden posters – Print one copy (8 pictures)

Lesson 8: Pest Control

Plants That Naturally Repel Insects cards – Print one set per group, cut into 11 strips

Bat House* – Print one copy

Insect Hotel* – Print one copy

Beneficials and Pests Insects cards – Print one set per group, cut the 24 cards

Leaf Damage cards – Print one set per group, cut into 8 strips

Hoop House* – Print one copy

Paper Barrier – Print one copy

Non-Toxic, Homemade Remedies cards – Print one set per group

Lesson 9: An Integrated Farm

Gift or Trash Posters – Print one copy of each page - 7 posters

Lesson 10: Working Together to Glorify God

Learning More Cards – Print and cut apart the 10 cards

Lesson 2: Who Rules Over Creation Role Play

For the role play, earlier in the day, ask three to four people to play the role of the farmers (men, women, and children) and two to three people to play the role of the rats. Read the story to them and explain their role to act out as you read the story.

Who Rules Over Creation?

In a village in the mountains of South America there was a common problem that the people faced. For generations, the people planted and harvested corn. Every day the men, women, and children went out to work the fields.

("Farmers" should act out all the work that it takes to prepare, plant, and harvest the corn). They prepared the soil. They carefully planted the seeds. They made sure the seeds had enough water and nutrients so they would grow.

Farming was hard work *(The men sweating and wiping their brow, the women having sore backs, and the children complaining of being too tired).* This took everyone's help, so often the children couldn't go to school. No matter how hard they worked, it always seemed like they didn't have enough to eat throughout the year.

Meanwhile, there was also a family of fat and happy rats that lived in the village. All day the rats sat in the cool house, the older rats taking naps and reading the newspaper, and the little rats running around playing. They enjoyed their easy life, especially during harvest season, because they could eat all the corn they wanted and take enough to store it for later where the humans wouldn't find it.

Farming



Caring for Animals

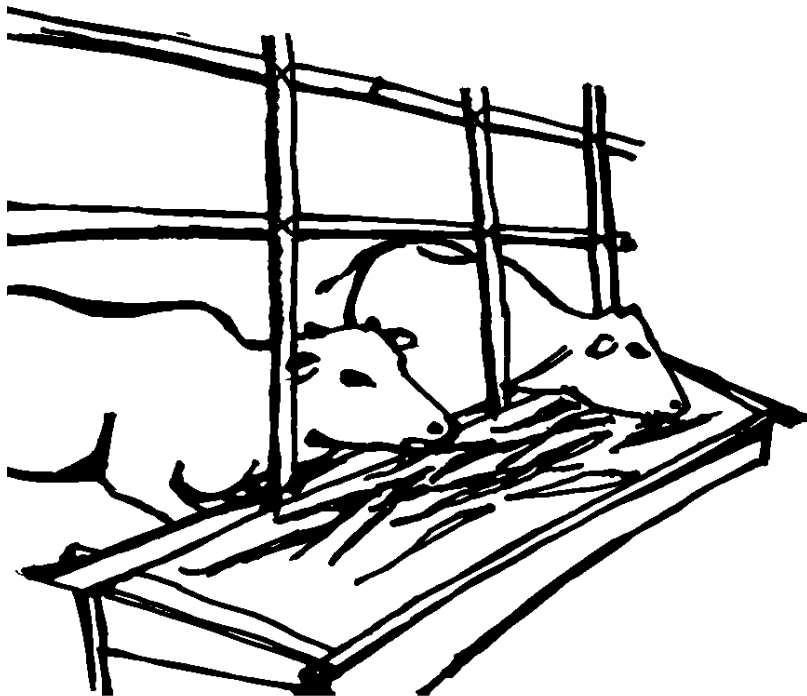

Building a House

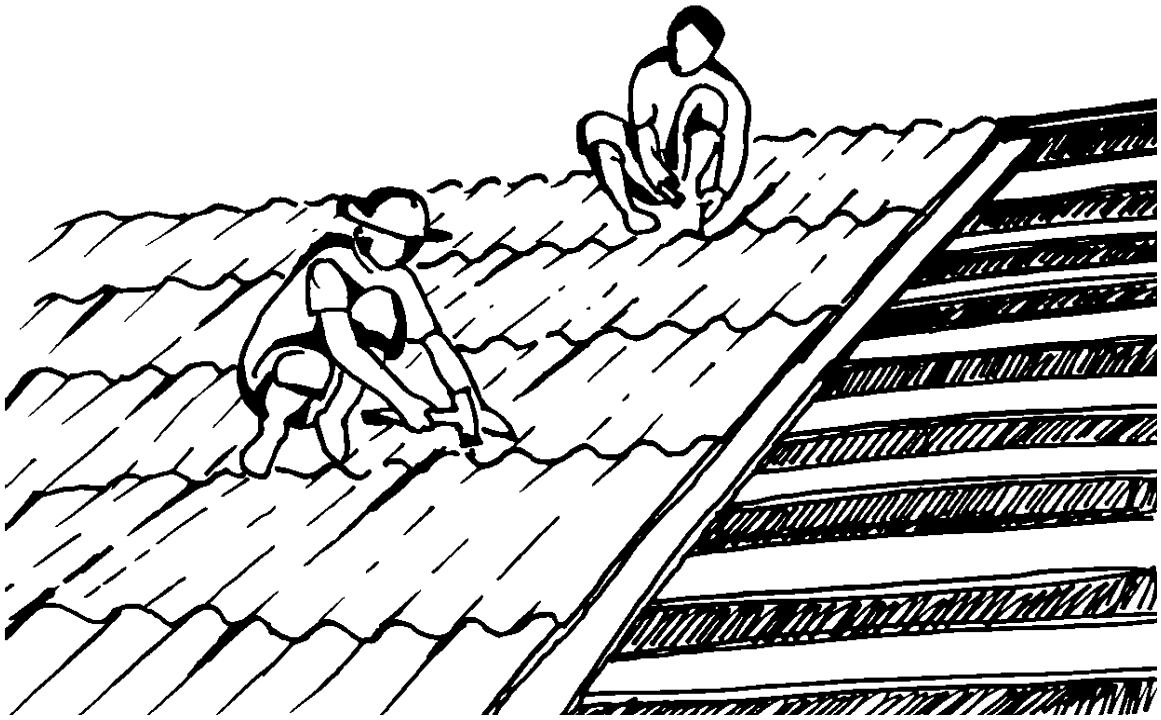

Fly Trap

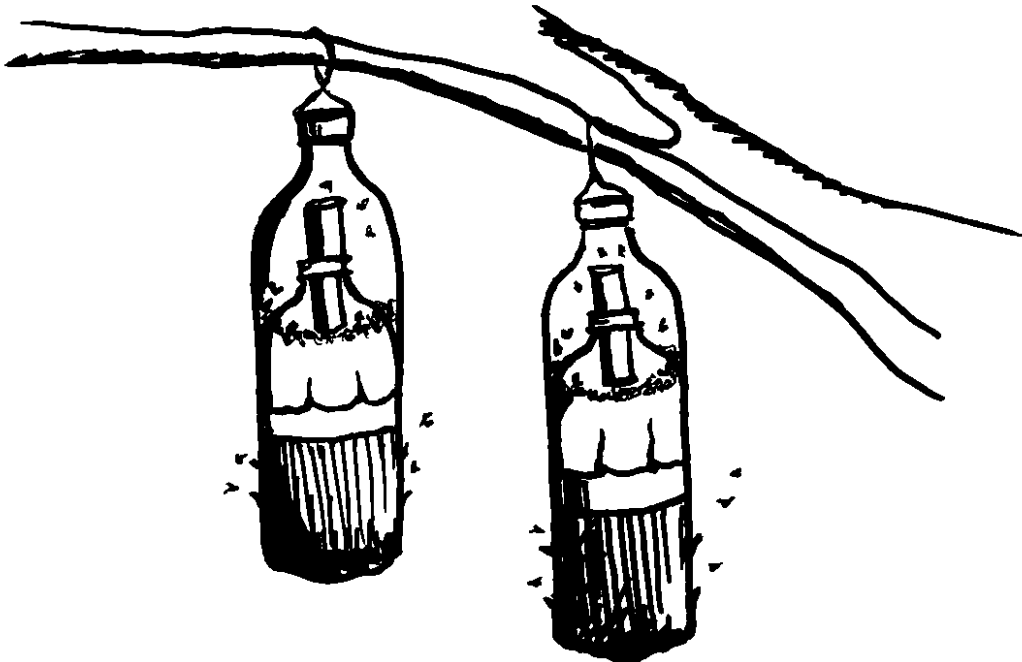

Rat Traps

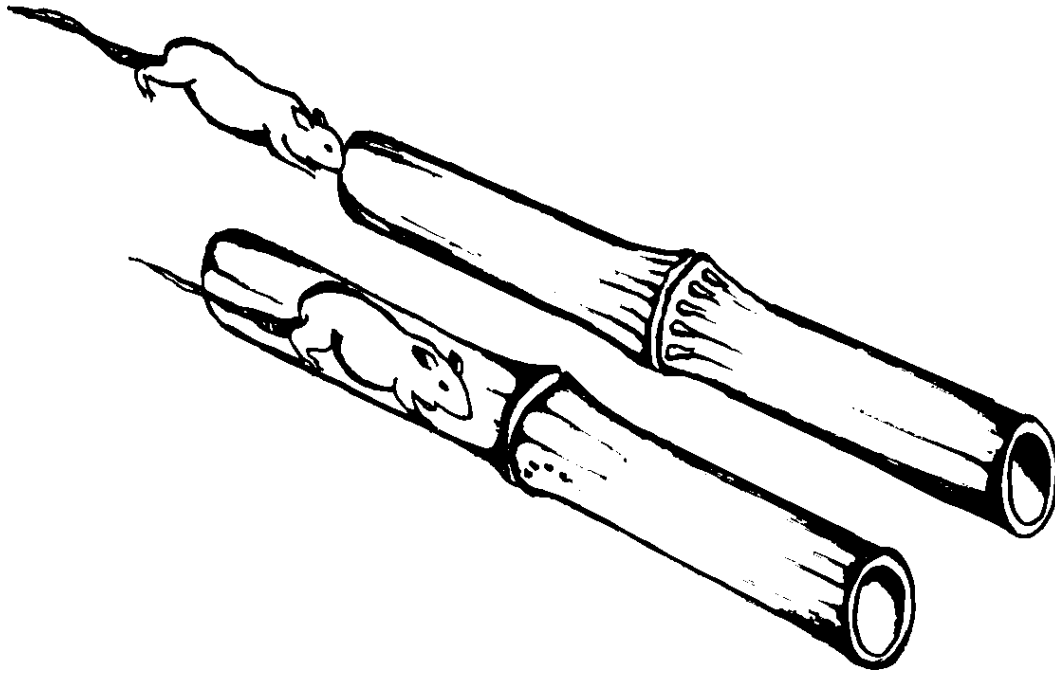

Not Cutting Too Many Trees



Clean Water

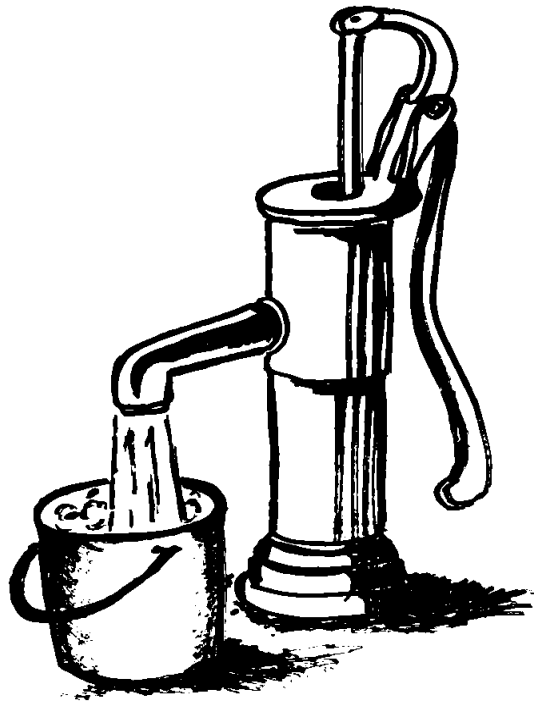

Digging a Well



Latrine

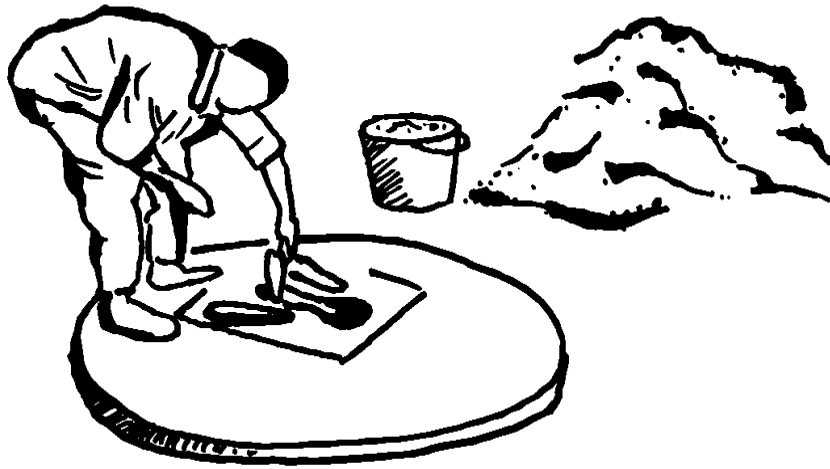

Litter



Growing Vegetables



Mosquito Net

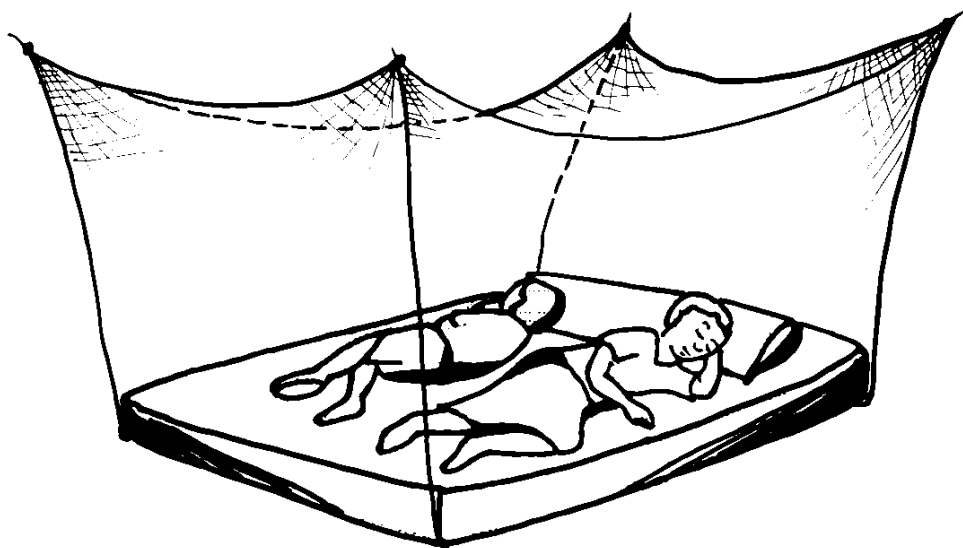

Lesson 5: What is in Soil?

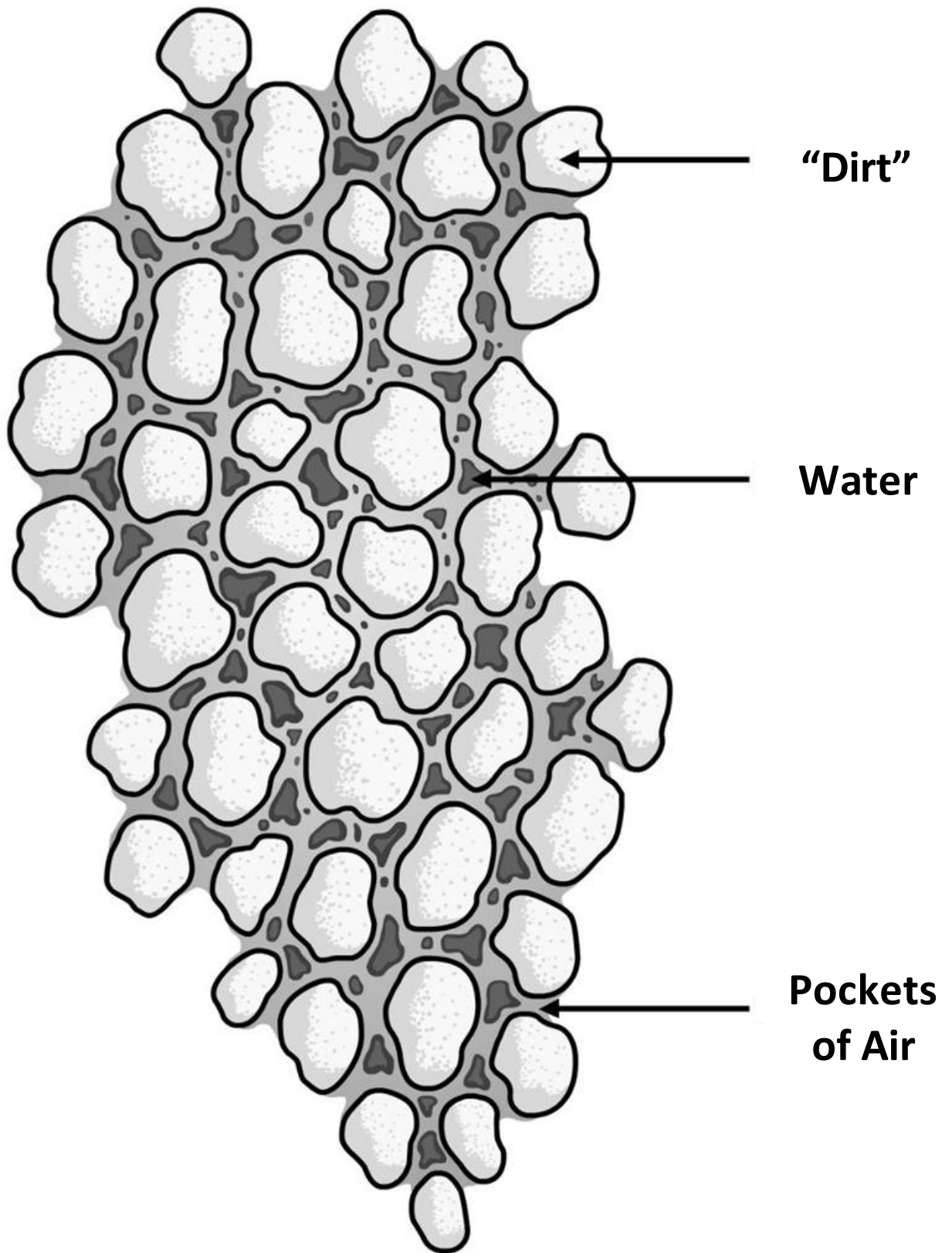

Lesson 5: Dibble Sticks

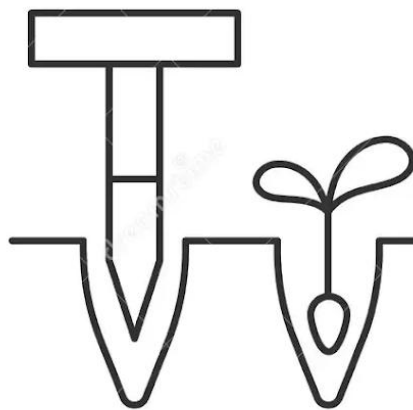

Lesson 5: Narrow Slots or Strips Using a Ripper

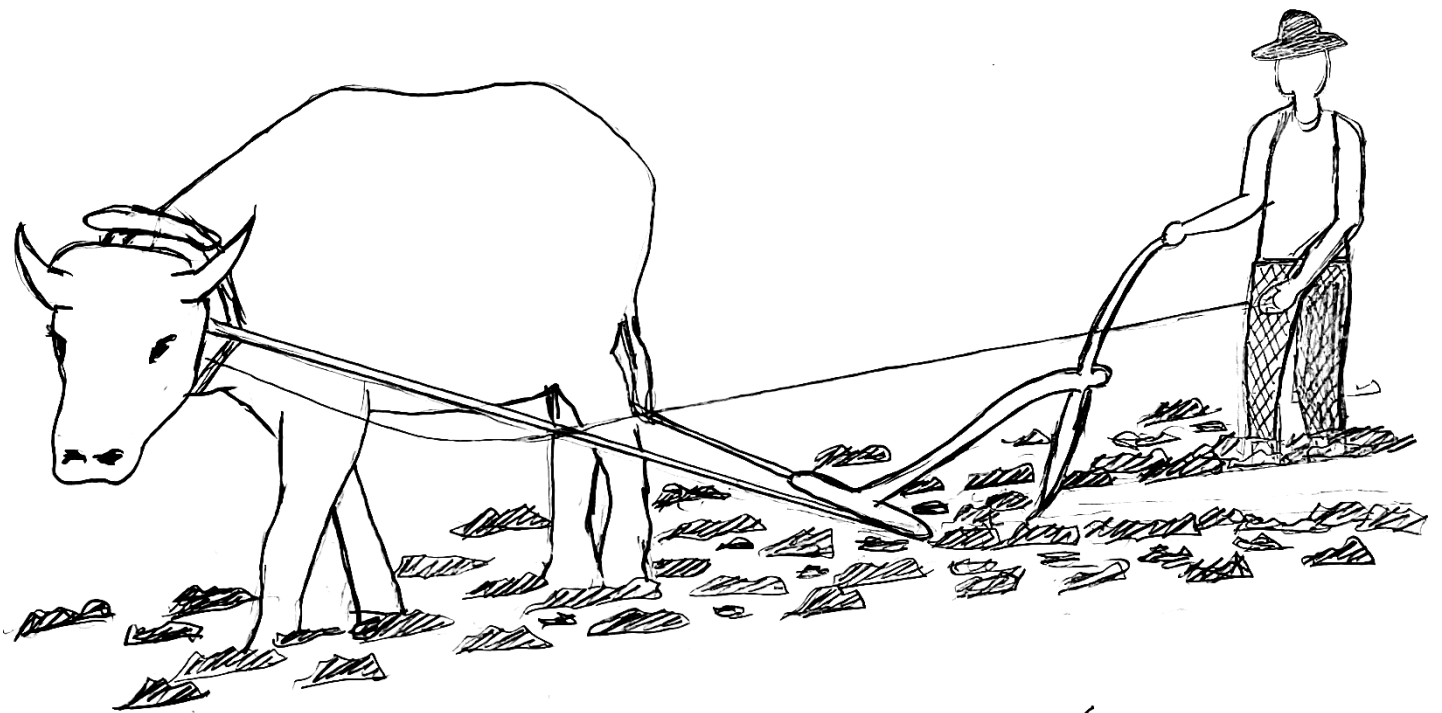

Lesson 5: Small Planting Holes or Pits

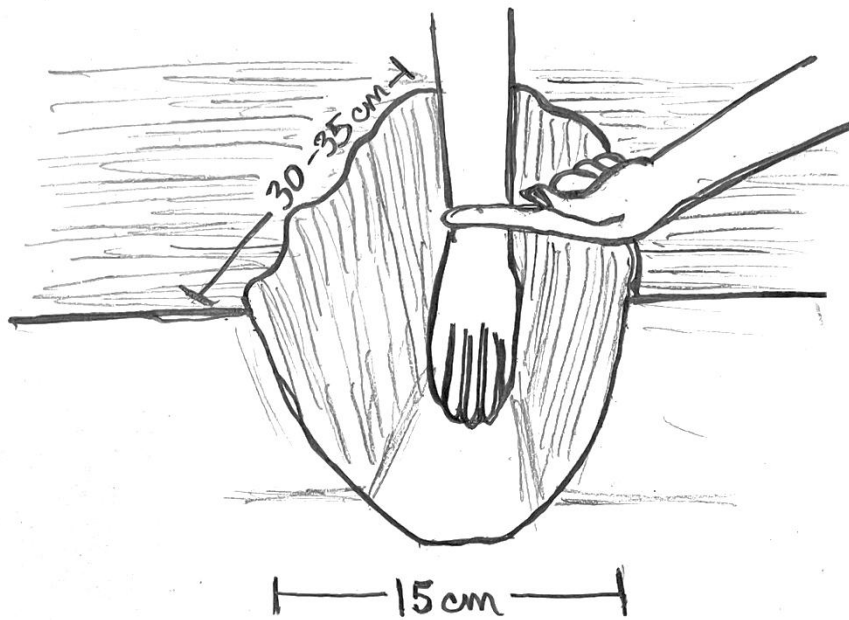

Lesson 5: Common Green Manure Cover Crops (GMCC) with Planting Instructions

Common name	Spacing (cm) * Inter-row spacing	Seed per hole	Seed rate (kg/ha)
Groundnut or Bambara groundnut	50 x 10	2	
Wild peanut	50 x 10	2	
Pigeon pea	50 x 40	2	
Calopo	30		30
Jackbean	50 x 50	2	
Tanzanian sunnhemp	30		30
Sunnhemp	30		45
Greenleaf and Silverleaf desmodium	30		30
Horsegram	broadcast		45
Hyacinth bean	60 x 30	2	
Buckwheat	broadcast		95
Soybean	50 x 5	2	
Perennial soybean	30*		30
Sweet white lupine	30 x 15	2	
Siratiro	30		30
Lucerne, alfalfa			30
Barrel medic			28
Velvet bean	60 x 30	2	
Glycine	30		30
Pea, garden pea, field			150
Lima bean	50 x 15	2	2
Common bean	50 x 15	2	2
Tropical kudzu			30
Stylo	30		30
Clovers: Berseem, Arrowleaf, or White Sweet, Subclover	30		30
Purple vetch	30		67
Faba bean	30 x 15	2	
Lana woolly pod vetch or common vetch or Hairy vetch	30		67
Green gram	50 x 5	2	
Cowpea	50 x 20	2	

Lesson 6: Nutrient Cycle

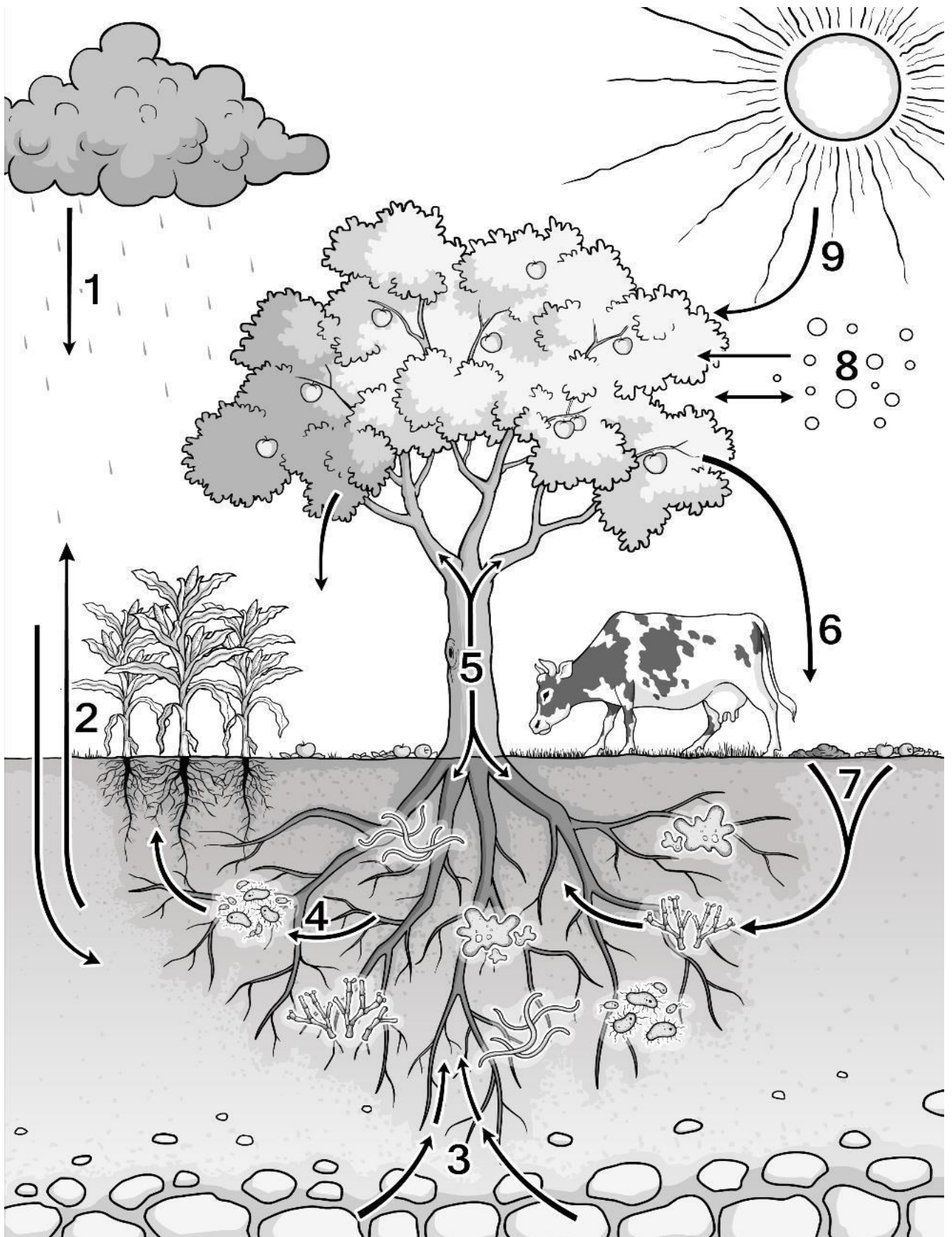

Lesson 6: Nutrients by Stage Chart









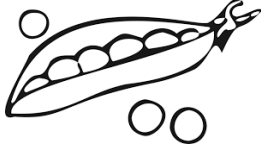

NUTRIENTS	GROWING 	CHANGE OVER 	RIPENING 
Nitrogen (N)	High	Low	Low
Potassium (K)	Low	Medium	Medium-High
Phosphorus (P)	Low	High	Medium
Calcium (Ca)	Low	High	Medium

Lesson 6: Nutrients & Stages

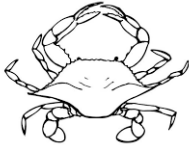

Cards

When plants develop their roots and shoots	Plants begin flowering at this point	The fruit begins to ripen on the plants
Infant plants	Adolescent plants	Adult plants
Requires a high amount of Nitrogen to stimulate growth	Plants need Phosphorus and Calcium	Plants need a high amount of Potassium for colour development and some Phosphorus and Calcium
Requires a low amount of Potassium, Phosphorus and Calcium	Plants need some Potassium and very little Nitrogen	A very low amount of Nitrogen is needed
Growing Stage	Cross-Over Stage	Ripening Stage

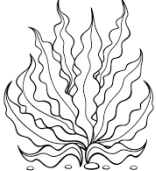
Lesson 6: Adding Nutrients

<p>Peas and Beans</p>  <p>Nitrogen</p>	<p>Composted Manure</p>  <p>Nitrogen</p>	<p>Coffee Grounds</p>  <p>Nitrogen</p>
<p>GMCCs</p>  <p>Nitrogen</p>	<p>Banana Peels</p>  <p>Potassium, Phosphorus</p>	<p>Crab Shells</p>  <p>Phosphorus</p>
<p>Shrimp Peelings</p>  <p>Phosphorus</p>	<p>Grains and Nuts</p>  <p>Phosphorus</p>	<p>Eggshells</p>  <p>Calcium</p>
<p>Fireplace wood ash</p>  <p>Calcium, Potassium</p>	<p>Kelp</p>  <p>Potassium</p>	<p>Seaweed</p>  <p>Potassium</p>

Lesson 6: Organic Materials for Each Stage of Growth

GROWING 	CHANGE OVER 	RIPENING 
Nitrogen (N) Peas, beans, composted cow and chicken manure, coffer grounds, other GMCCs	Phosphorus (P) Calcium (Ca) <i>some Potassium (K)</i>	Potassium (K) some <i>Calcium (Ca) &</i> <i>Phosphorus (P)</i>
	banana peels, crab shells, shrimp peelings, grains and nuts eggshells, fireplace wood ash, kelp and seaweed	banana peels, crab shells, shrimp peelings, grains and nuts, eggshells, fireplace wood ash, kelp and seaweed

Lesson 6: Making Your Own Fertiliser

Procedure

- On a clean floor, mix 20 kg manure, and 20 kg maize husks or dead leaves. (Use manure from small animals like goats and poultry, not cow or horse manure.)
- Add 10 kg wood ash and mix again.
- ****Optional Step:** We do not recommend you purchase chemical fertilisers, but if you ALREADY have some, you can add a small amount to your organic fertiliser at this time (5kg CAN or 5 kg Urea Chemical Fertiliser)
- Add 5 litres of urine (animal or human) or water. Mix everything very well.
- Put the mixture in a large plastic bag. Put the bag inside a sack and tie it tightly so that no air can get in or out. Keep it in a covered area for 21 days.
- After 21 days, open the sack. Be careful not to look into it! The smell and the air that comes out is very strong. Dry the fertiliser in the shade for 2 hours and then put it back into the sack for storage or use it right away.

Test your fertiliser on a small section of your crop before using it on all your crops. A small amount of fertiliser and organic matter can make a big difference.

Other Useful Organic Materials to Add to Your Fertilizer:

These organic materials break down slowly and will not harm your soil.

- Banana peels – Cut up one or two peels into small pieces. Add to fertiliser mix. Adds POTASSIUM.
- Coffee grounds – Sprinkle used coffee grounds on top of the soil before watering plants. Adds NITROGEN. Especially good for tomatoes and flowers.
- Eggshells – Wash, then crush. Work the shell pieces into the soil near tomatoes and peppers. Eggshells add CALCIUM, which helps fend off blossom end rot.
- Peas and beans and other GMCCs – Mash, then add to the soil.
- Seaweed – Chop up a small bucket of fresh or dried seaweed. Add to 5 gallons of water. Let sit for 2-3 weeks loosely covered. Drench the soil and foliage with 2-6 cups, depending on the size of the plant.

Lesson 7: All-Year Food Garden

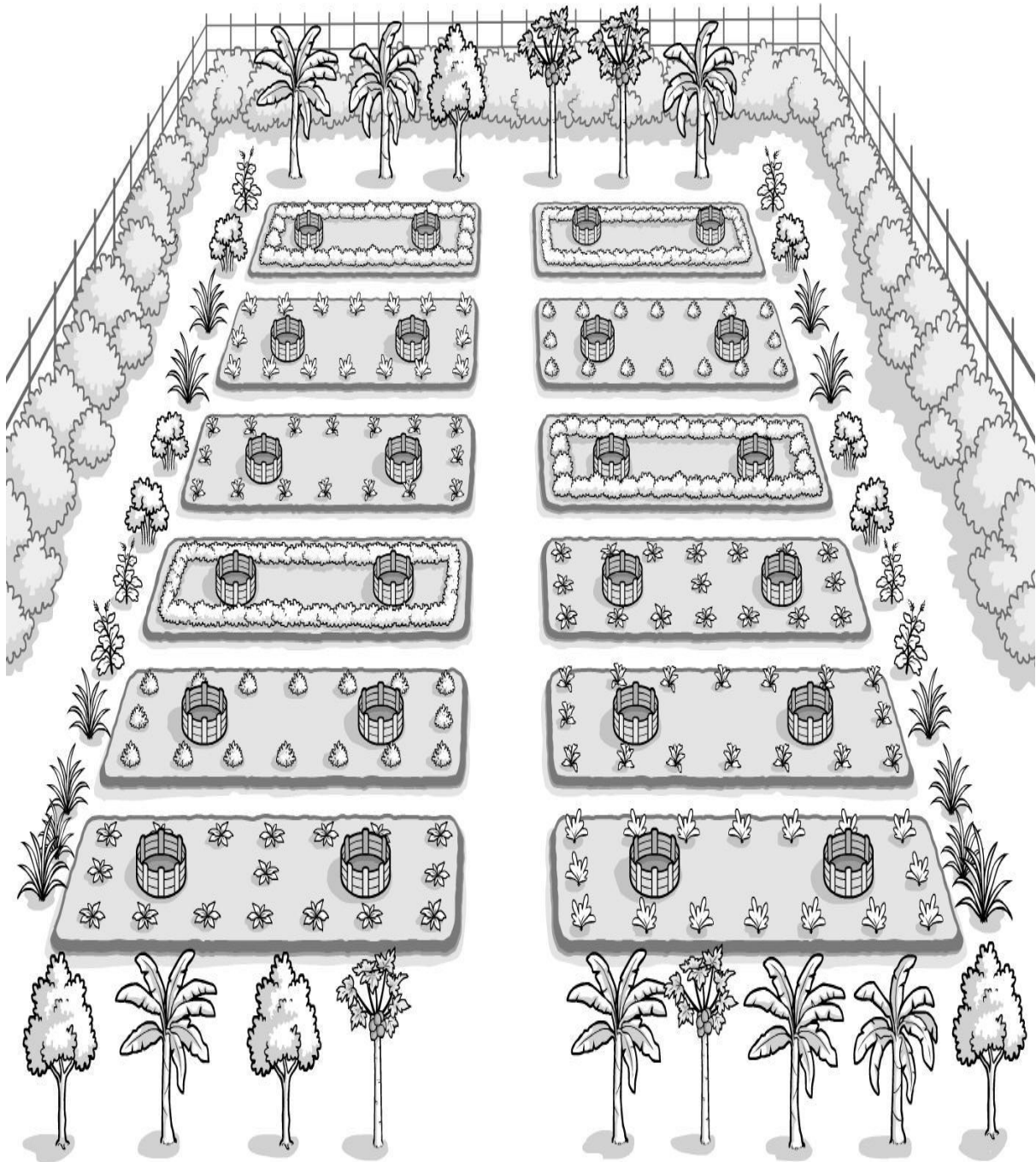

Lesson 7: Ten Steps to Make an All-Year Food Garden

Step 1 – Locate the best site for the garden

Step 2 – Provide enough space

Step 3 – Thoroughly prepare the soil

Step 4 – Attract Earthworms

Step 5 – Plant 1/3 of the garden with early maturing vegetables

Step 6 – Plant next 1/3 with semi-annual vegetables

Step 7 – Plant last 1/3 with annual vegetables

Step 8 – Plant the surrounding area of the garden with permanent crops

Step 9 – Plant reserved portion on time

Step 10 – Practice Crop Rotation

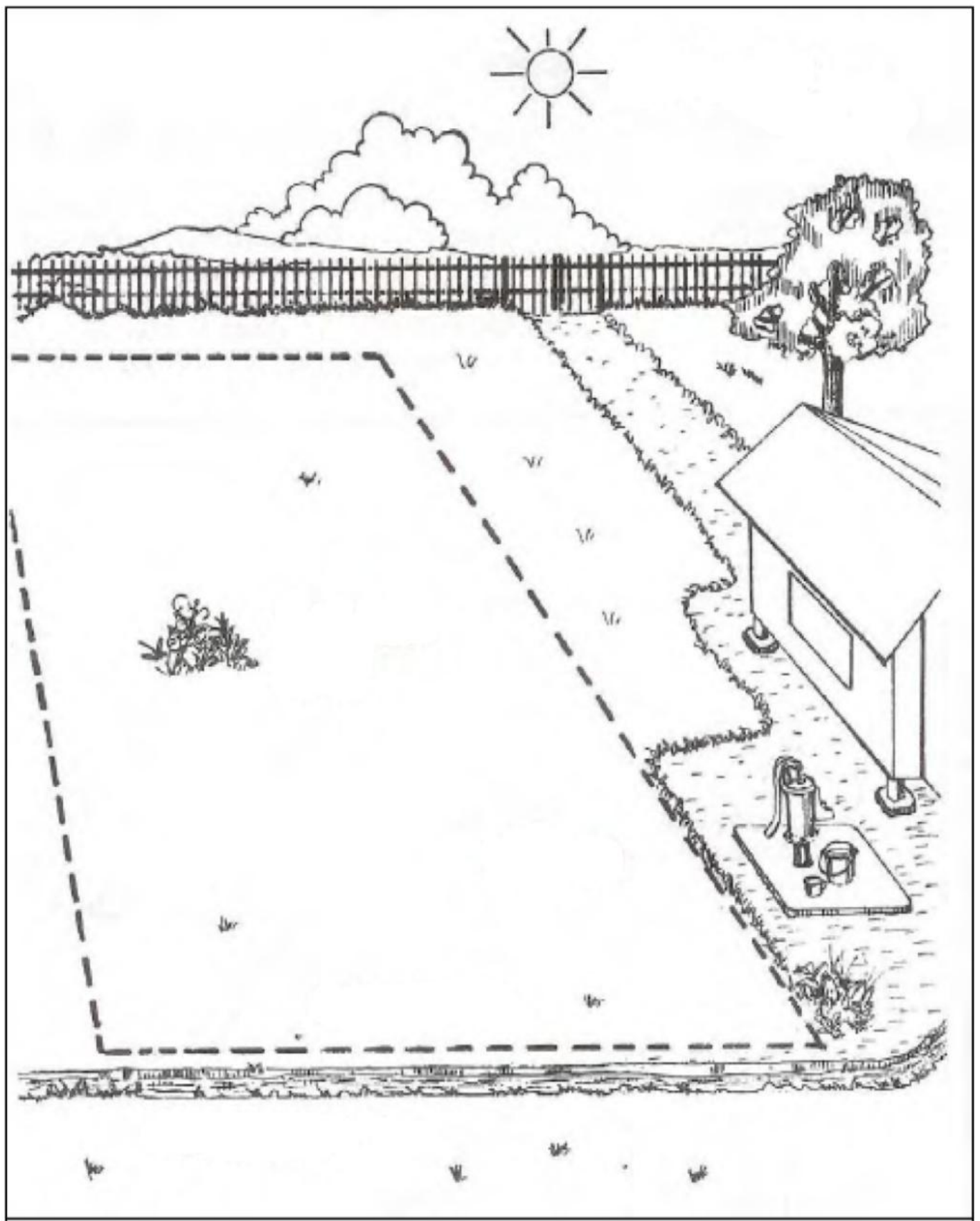

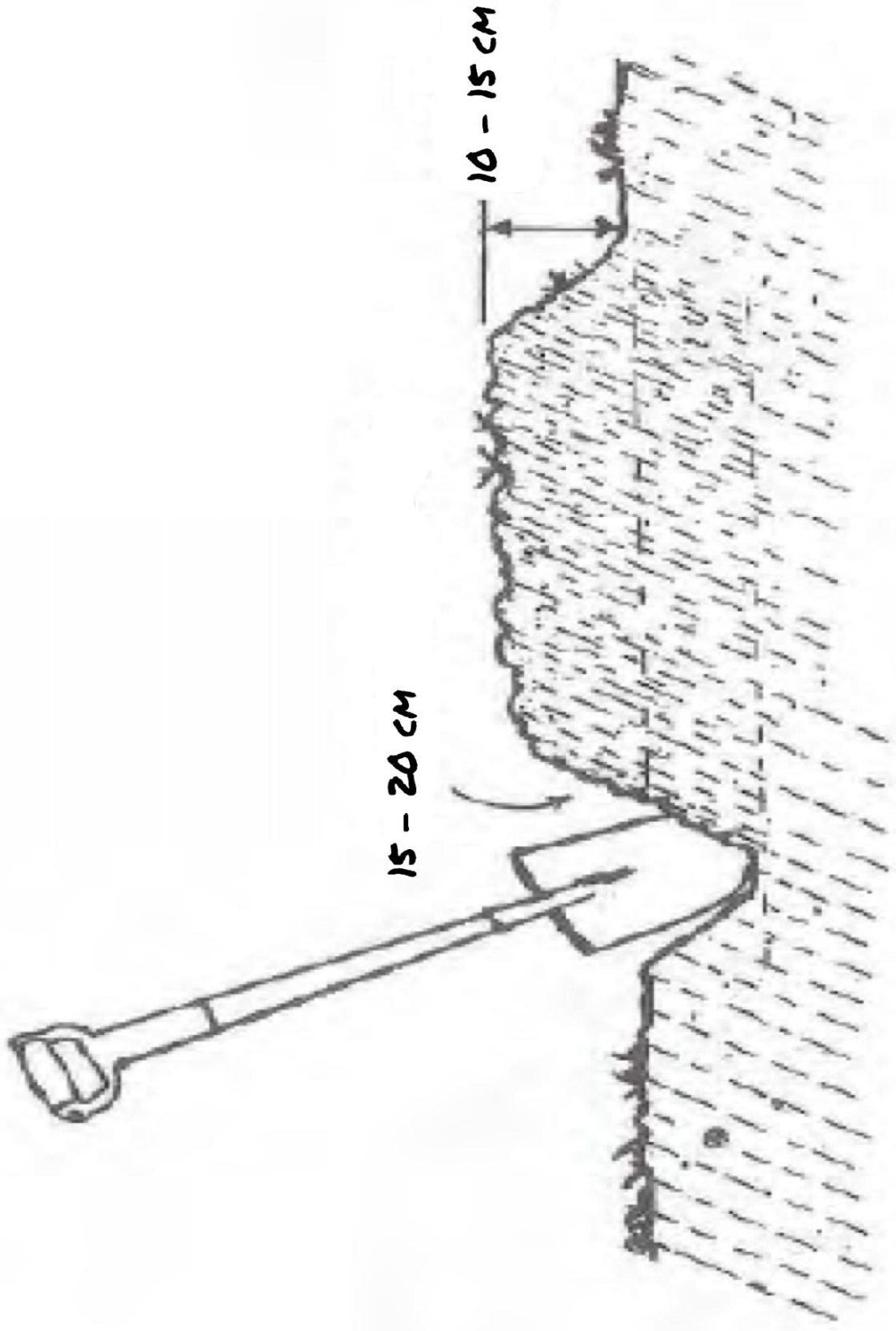

10 - 15 CM

15 - 20 CM

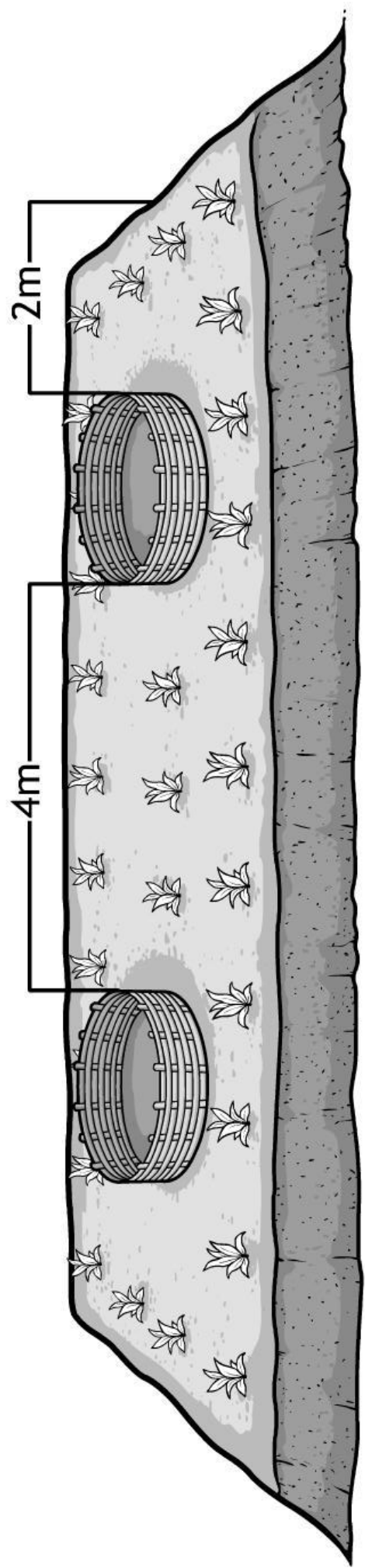
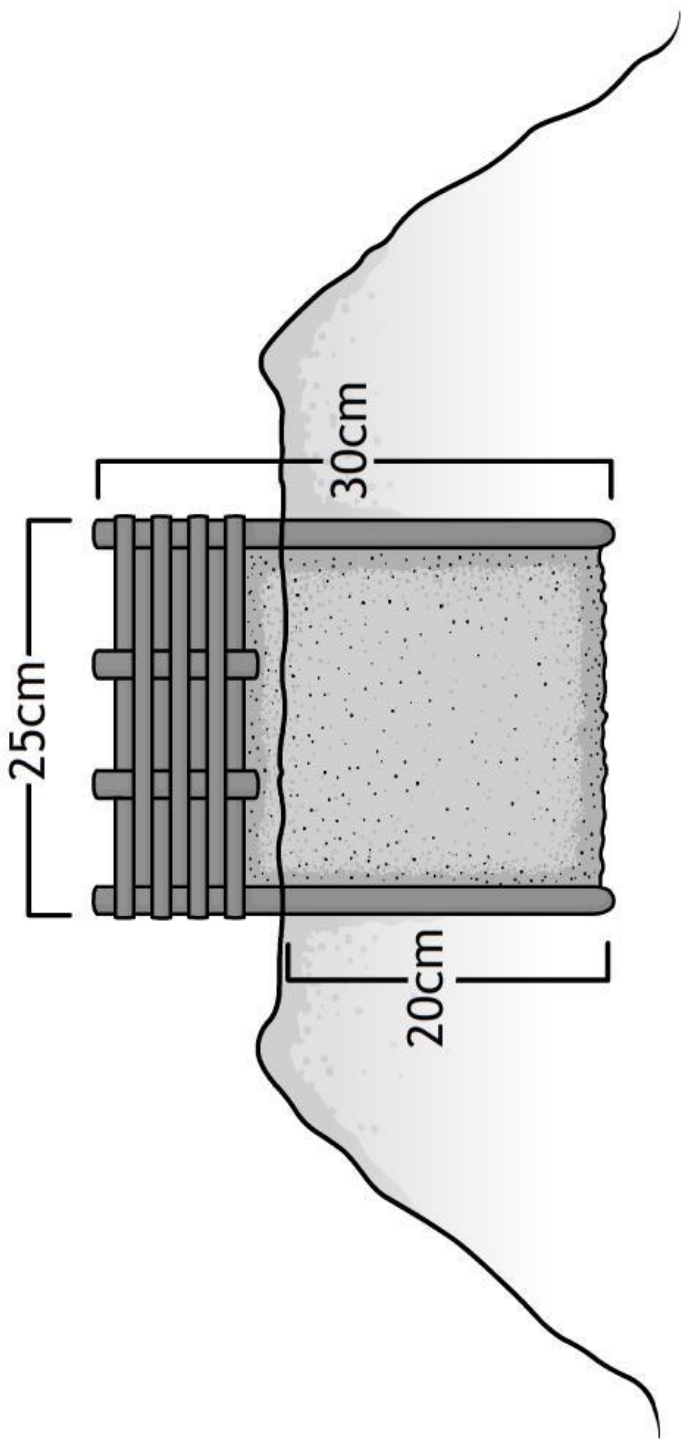

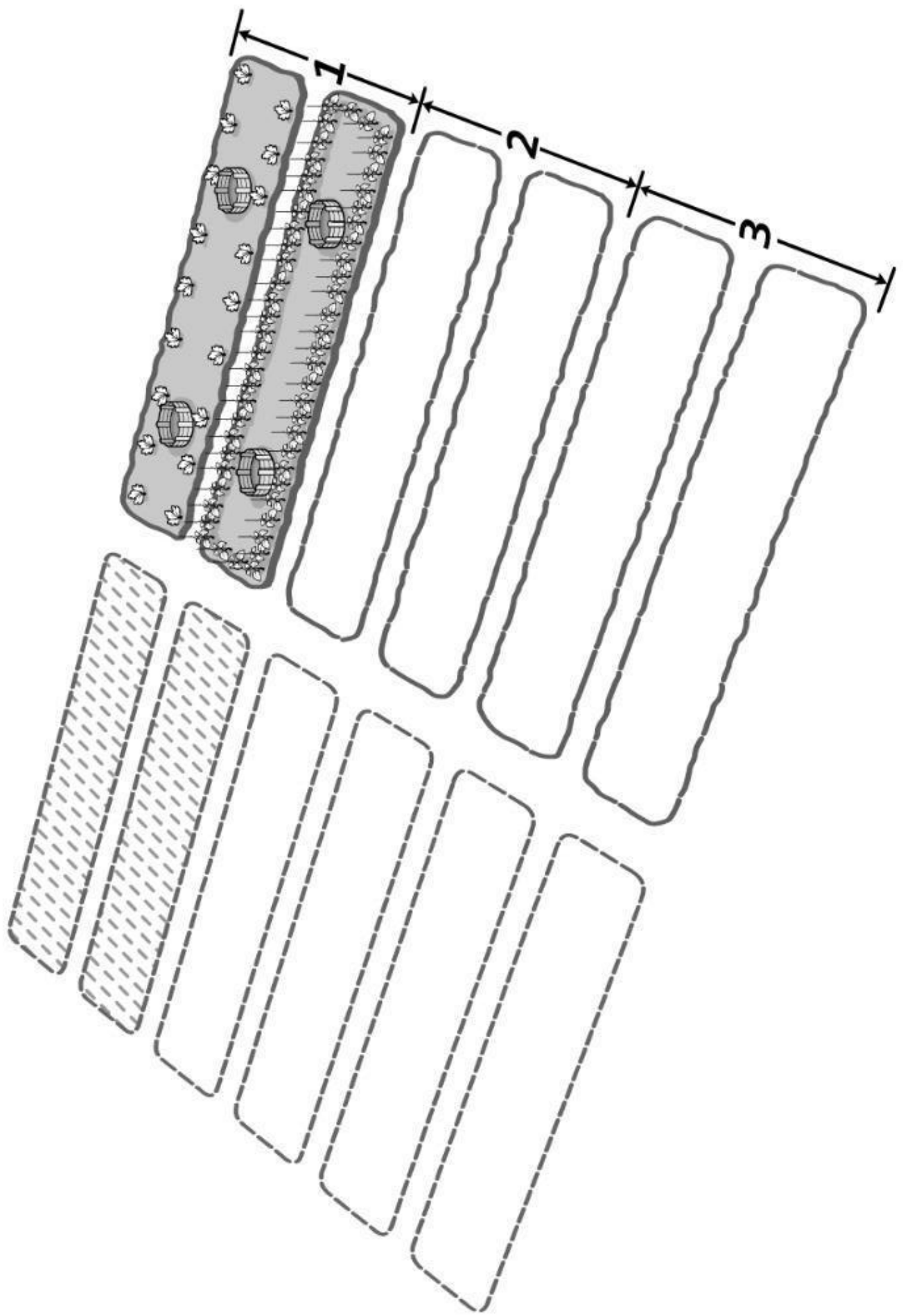

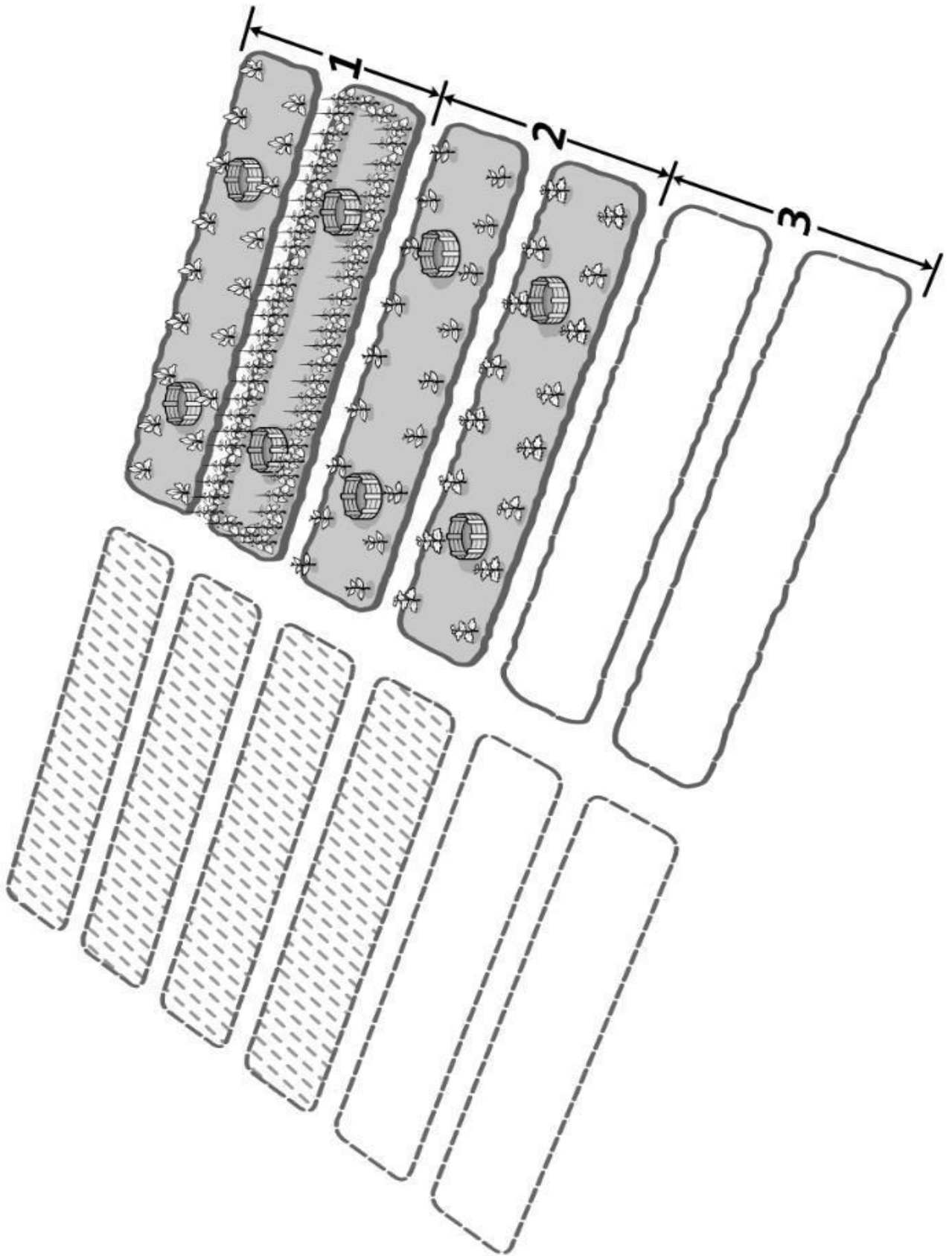

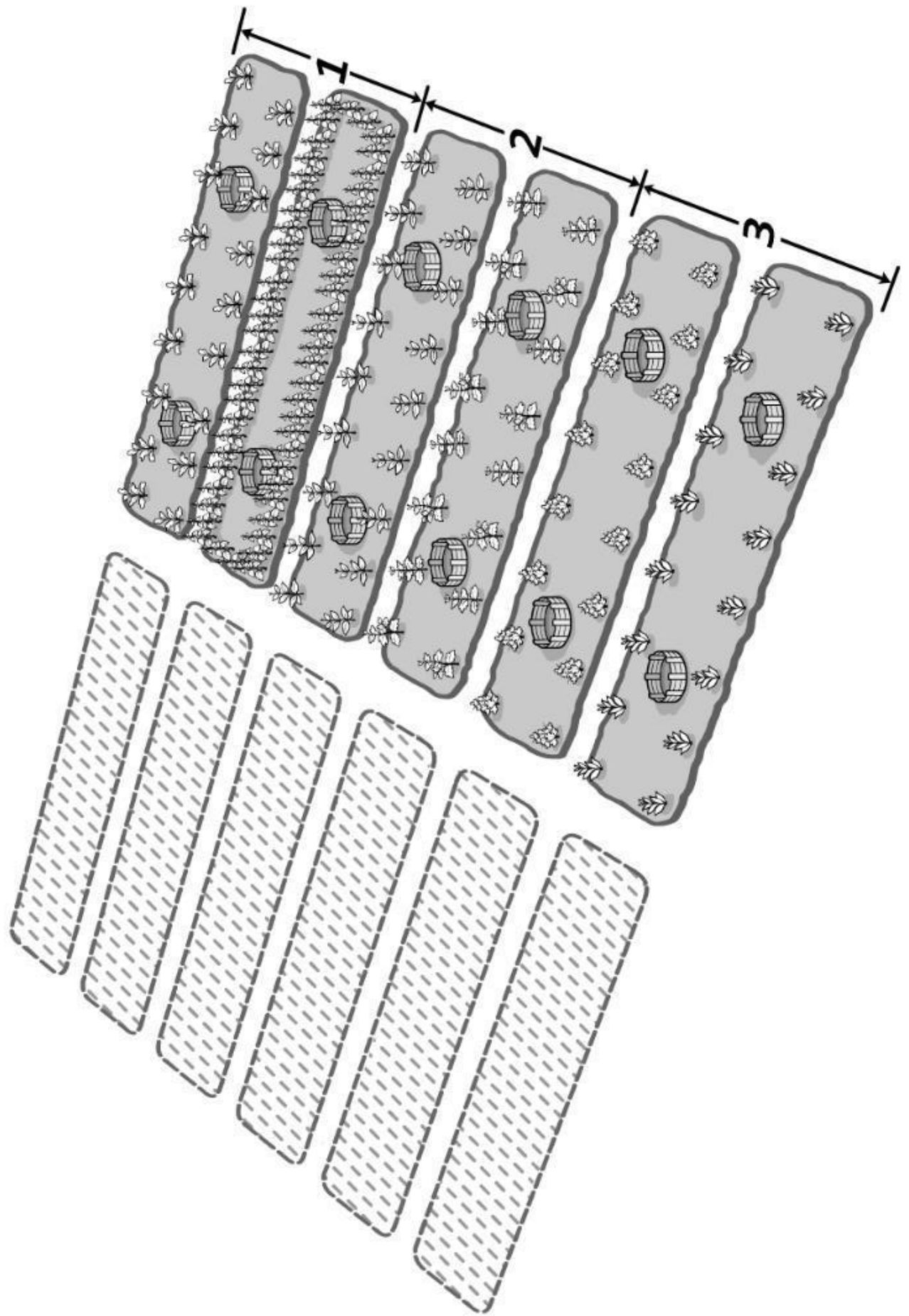

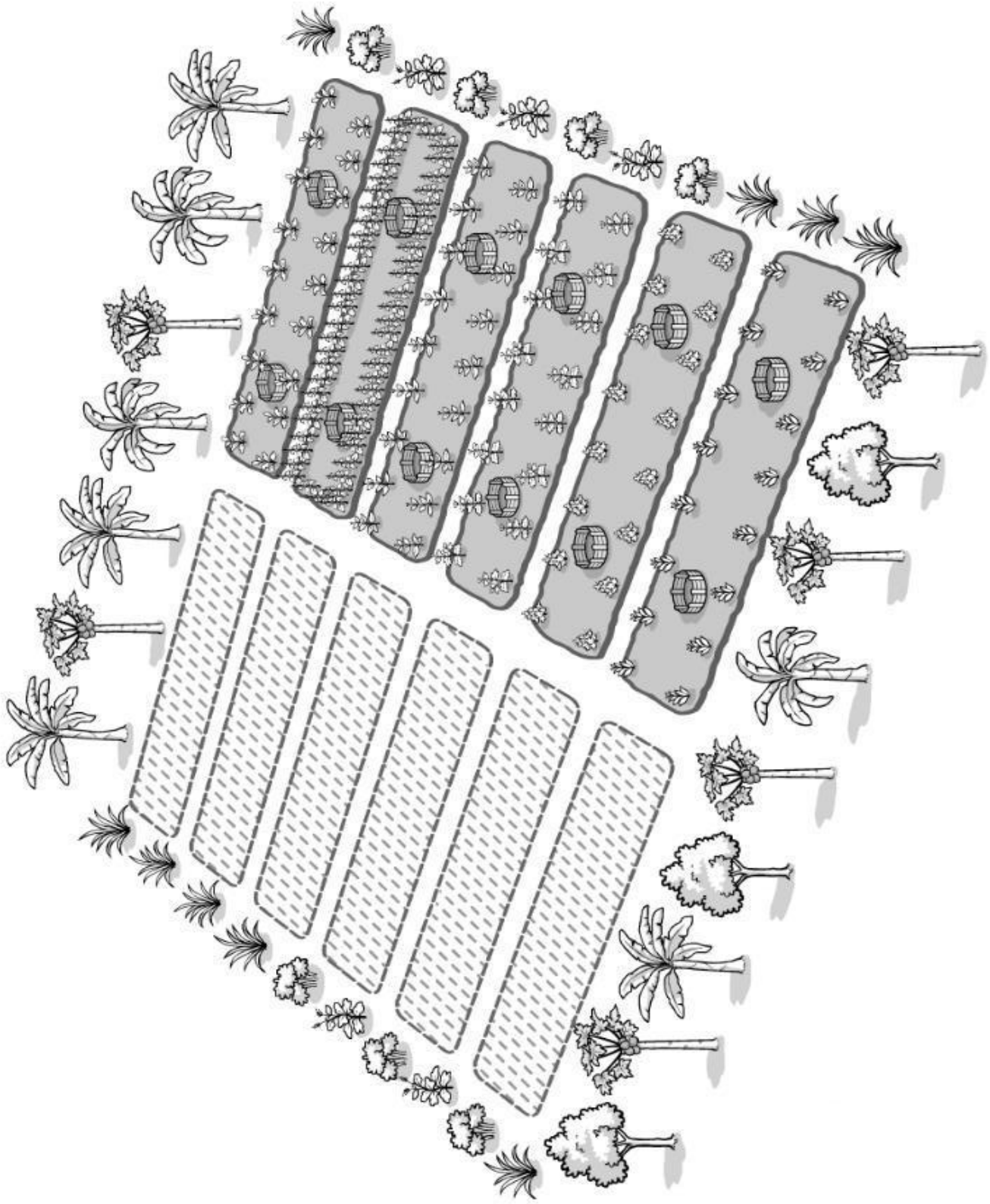

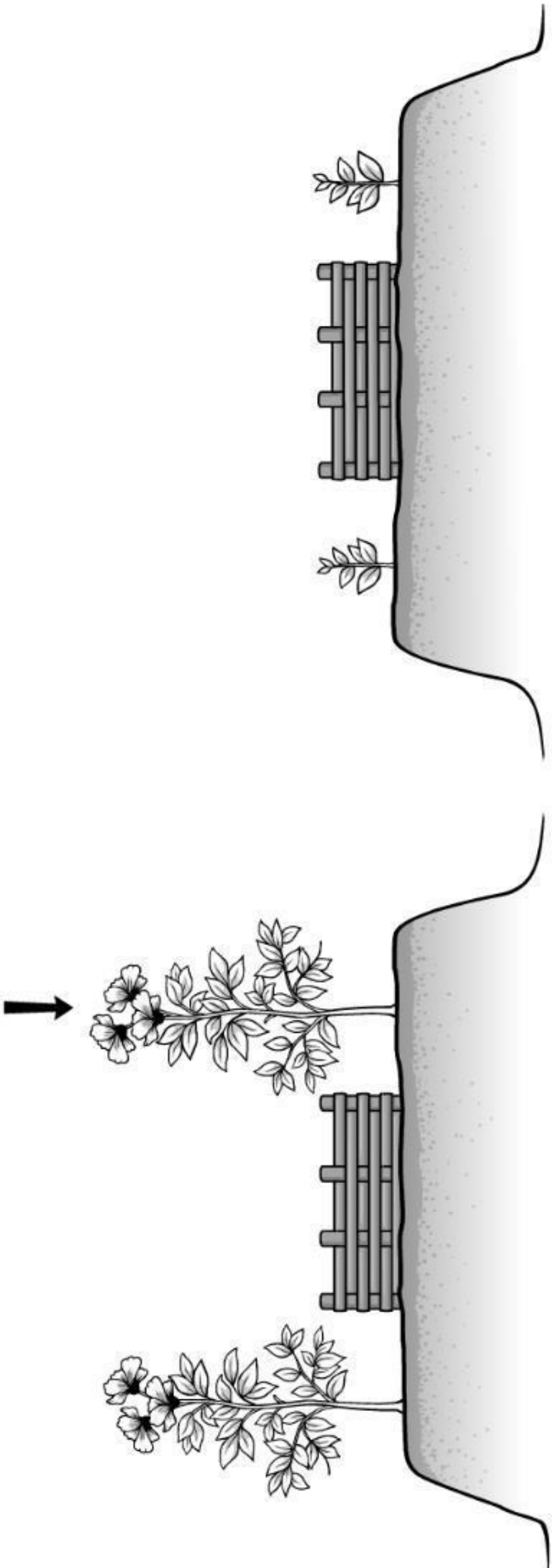



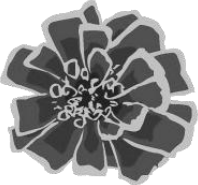







Lesson 8: Plants that Naturally Repel Insects Cards



Plant	To Repel
<p data-bbox="416 667 550 696">Marigolds</p> 	<p data-bbox="1007 667 1273 696">Mosquitoes, aphids</p> 

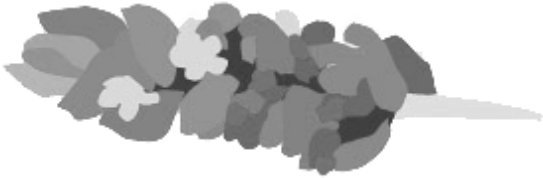

Plant	To Repel
<p data-bbox="400 1077 566 1106">Nasturtiums</p> 	<p data-bbox="855 1077 1426 1149">Whiteflies, cabbage loopers, aphids, many beetles, squash bugs</p> 



Plant	To Repel
<p data-bbox="424 1518 542 1547">Petunias</p> 	<p data-bbox="826 1518 1453 1590">Aphids, asparagus beetles, leafhoppers, squash bugs, tomato hornworms</p> 

Plant	To Repel
<p data-bbox="448 275 515 304">Basil</p> 	<p data-bbox="979 275 1299 304">Houseflies, mosquitoes</p> 

Plant	To Repel
<p data-bbox="421 714 544 743">Lavender</p> 	<p data-bbox="933 714 1347 743">Moths, fleas, flies, mosquitoes</p> 



Plant	To Repel
<p data-bbox="172 1153 794 1223">Lemongrass, lemon thyme, lemon balm, mint, rosemary</p> 	<p data-bbox="1059 1153 1222 1182">Mosquitoes</p> 

Plant	To Repel
<p data-bbox="437 1601 529 1630">Thyme</p> 	<p data-bbox="826 1601 1455 1671">Whiteflies, cabbage loopers, cabbage maggots, corn earworms, whiteflies, tomato hornworms</p> 

Plant	To Repel
<p data-bbox="459 271 507 300">Dill</p> 	<p data-bbox="847 271 1433 338">Aphids, squash bugs, spider mites, cabbage loopers, tomato hornworms</p> 

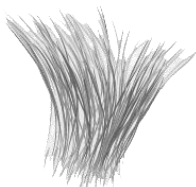
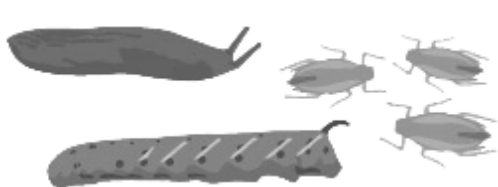
Plant	To Repel
<p data-bbox="437 759 529 788">Fennel</p> 	<p data-bbox="1007 759 1273 788">Aphids, slugs, snails</p> 

Plant	To Repel
<p data-bbox="177 1234 790 1263">Allium Family (chives, onions, leeks, shallots)</p> 	<p data-bbox="858 1234 1422 1263">Slugs, aphids, carrot flies, cabbage worms</p> 

Plant	To Repel
<p data-bbox="363 1711 603 1740">Chrysanthemums</p> 	<p data-bbox="847 1711 1433 1823">Roaches, ants, Japanese beetles, ticks, silverfish, lice, fleas, bedbugs, spider mites, harlequin bugs, root-knot nematodes</p> 

Lesson 8: Bat House Design

Begin with a rough, thin board, about 28cm x 2cm x 1.5m

Cut the board into the following pieces:

A: 45cm x 28cm

D: 10cm x 26cm

B: 30cm x 28cm

E1 and E2: 30cm x 13cm

C: 15cm x 28cm

F: 20cm x 25cm

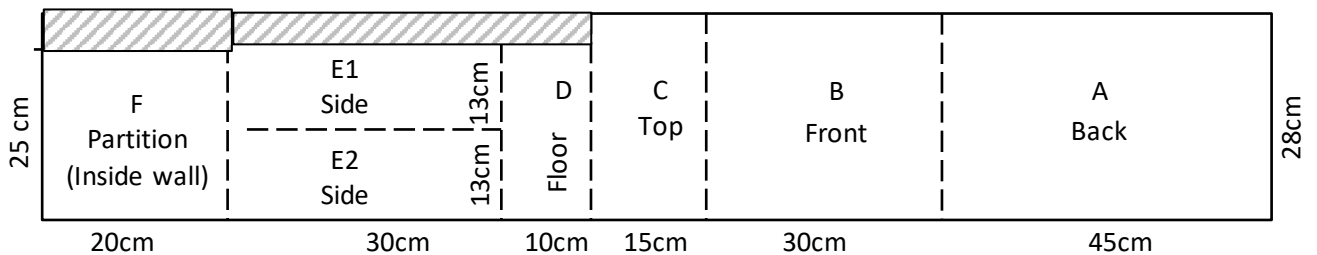

Use a rough board so the bats can hold onto the wood.

Use nails or screws to secure the pieces together as shown by the black dots in the diagrams. Mount on a pole or the side of a building.

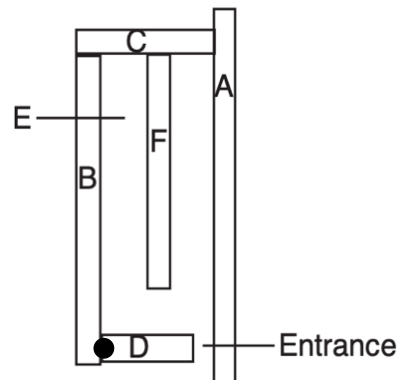
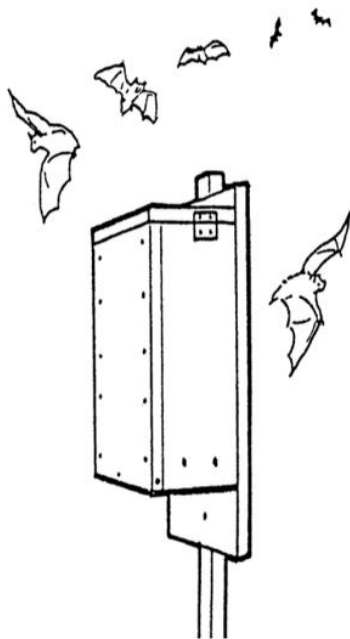

Lesson 8: Insect Hotel

Insect hotels don't need to cost anything except time. You can use material that you already have such as boards, pallets, newspaper, straw, plastic bottles, bamboo, pipes, tin (or other roofing materials) and even rotting logs.

Provide a roof and walls so that after rain, water will not get into the insect hotel. Most insects like slightly damp conditions but not soggy.

One end of the structure should be open, and the inside should be stuffed with a variety of materials. Insect hotels do best in a protected area away from a lot of wind.

Bees like sunny areas. Insects are also attracted to flowers and ponds in the area.

Different insects will be drawn to different materials.

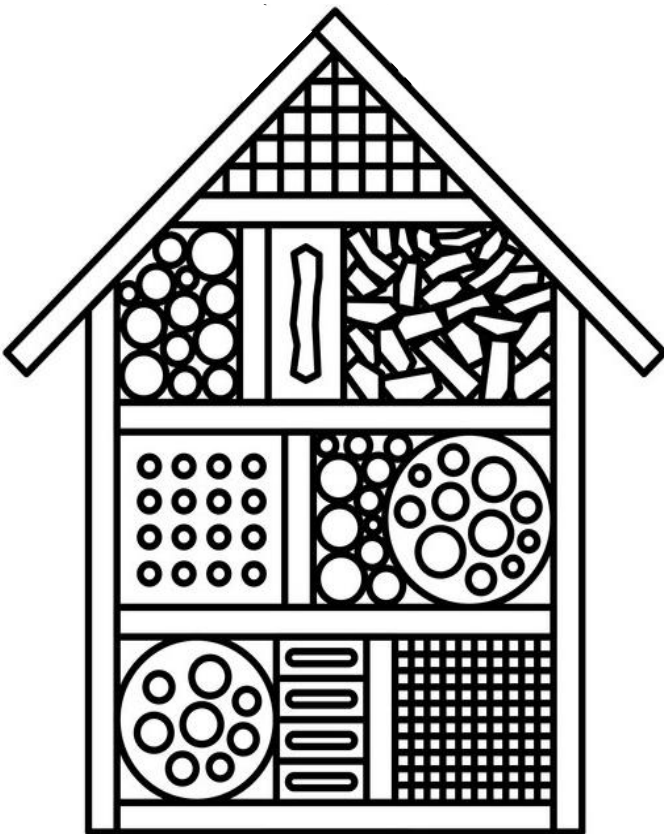

Rotting logs – perfect for wood-boring beetles. Put at the base of the structure so that the wood stays damp and will mix with other decaying material in the soil. This will also attract good centipedes and other good insects.

Wood and Bamboo cane with drilled holes – Bees and wasps are attracted.

Twigs, sticks and stems – Bundle together in different sizes to attract ground beetles, hoverflies and ladybugs.

Straw, dried grass and rolled up newspaper or cardboard –

use to fill in the holes in hotel and attract other insects that protect our gardens from pests. These can be placed inside a plastic bottle with a big opening at one end to keep them dry.

Lesson 8: Beneficials and Pests Cards

Cabbage Moth

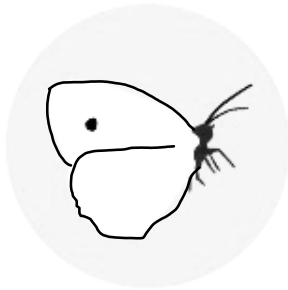

Cabbage Worm



Cutworm



Flea Beetle



Mite



Parsley Worm



Squash Vine Borer



Tomato Horn Worm



Carrot Rust Fly



Mexican Bean Beetle



Slugs & Snails



White Flies & Aphids



Ant

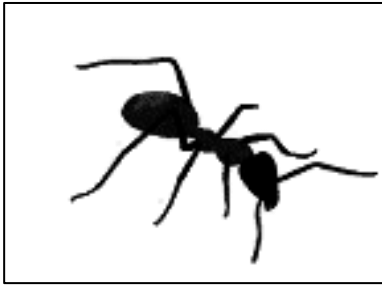

Bee



Earwig

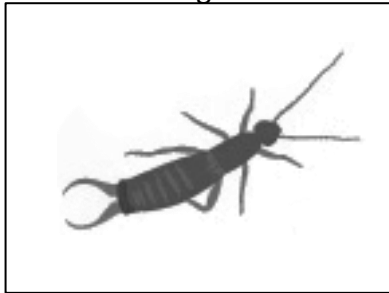

Green Lacewing

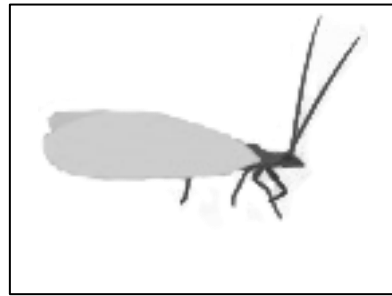

Ladybug



Parasitic Wasp

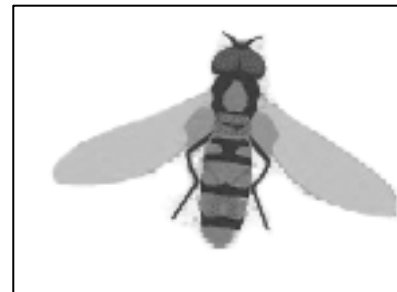

Centipede

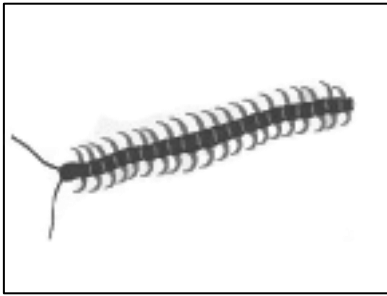

Ground Beetle

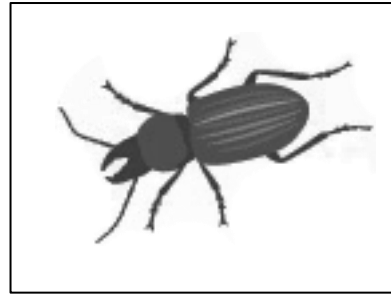

Praying Manti



Spider



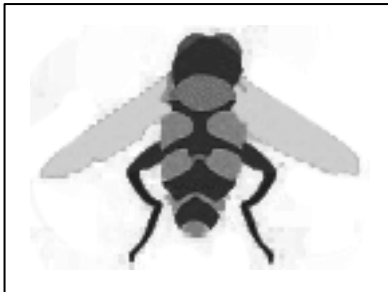

Predator Fly



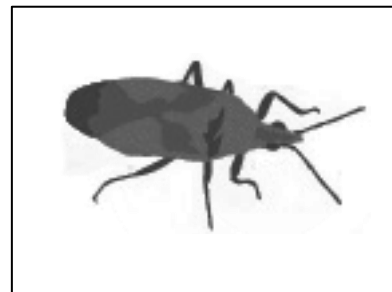

Small Pirate Bug







Lesson 8: Leaf Damage Cards



Damage	Pest
<p data-bbox="256 472 710 506">Deformed leaves, sucking damage</p> 	<p data-bbox="1091 472 1187 506">Aphids</p> 



Damage	Pest
<p data-bbox="252 875 715 909">Discolored leaves, sucking damage</p> 	<p data-bbox="1027 875 1251 909">Thrips and mites</p> 



Damage	Pest
<p data-bbox="276 1290 691 1323">Chewed or skeletonized leaves</p> 	<p data-bbox="916 1290 1362 1323">Beetles, caterpillars, and sawflies</p> 

Damage	Pest
<p data-bbox="244 1731 722 1765">Leaf galls (abnormal plant growths)</p> 	<p data-bbox="847 1731 1433 1765">Cynipid wasps, certain aphids, psyllids, and mites</p> 

Damage	Pest
<p data-bbox="229 271 735 304">Leaf mines (white patterns on leaves)</p> 	<p data-bbox="963 271 1315 304">Beetle, fly, or moth larvae</p> 

Damage	Pest
<p data-bbox="389 714 576 748">Folded leaves</p> 	<p data-bbox="884 714 1394 748">Caterpillars, tree crickets, and spiders</p> 

Damage	Pest
<p data-bbox="392 1158 572 1191">Rolled leaves</p> 	<p data-bbox="911 1158 1369 1191">Certain mites or some caterpillars</p> 

Damage	Pest
<p data-bbox="300 1601 667 1635">Chewed leaves, slime trails</p> 	<p data-bbox="1031 1601 1246 1635">Slugs and snails</p> 

Lesson 8: Hoop House

Hoop houses are constructed using basic materials such as PVC pipe or bamboo. They are reinforced with rebar or stakes to stabilize the frame in the ground. Twine or large zip ties are used to tie the frame together. A plastic sheet covers the structure, and cement blocks or big rocks to hold the plastic in place.

Outer frame - Put a door on each end by creating a wood frame and cover it with plastic. Secure the door to an arched pole by using twine or zip ties. Secure the ends with stakes or rebar buried at least one foot into the ground. Attach a cross beam from one end arch to the other. (You can add additional support by connecting a vertical pole at the centre of the frame.)

Attach enough arches for the structure to have good support (1m apart is good).



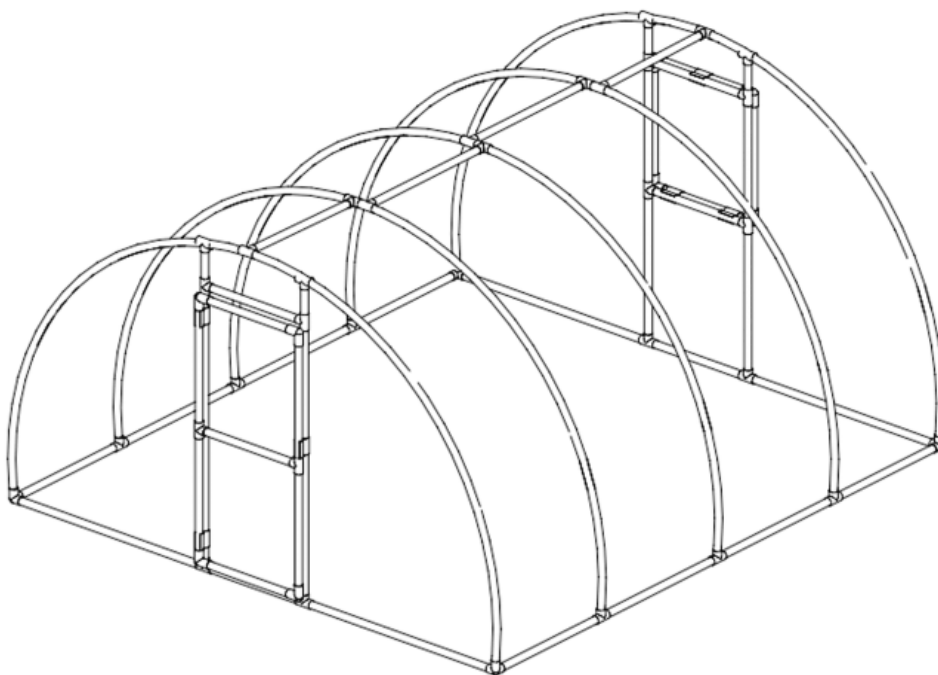

Cover the frame with plastic lining. Make sure you have extra on the sides and for the door and ends. It is best to have a person on each side to pull the plastic tight. Once the plastic is in place you can use long boards or cement blocks or rocks to hold the plastic in place at the base.

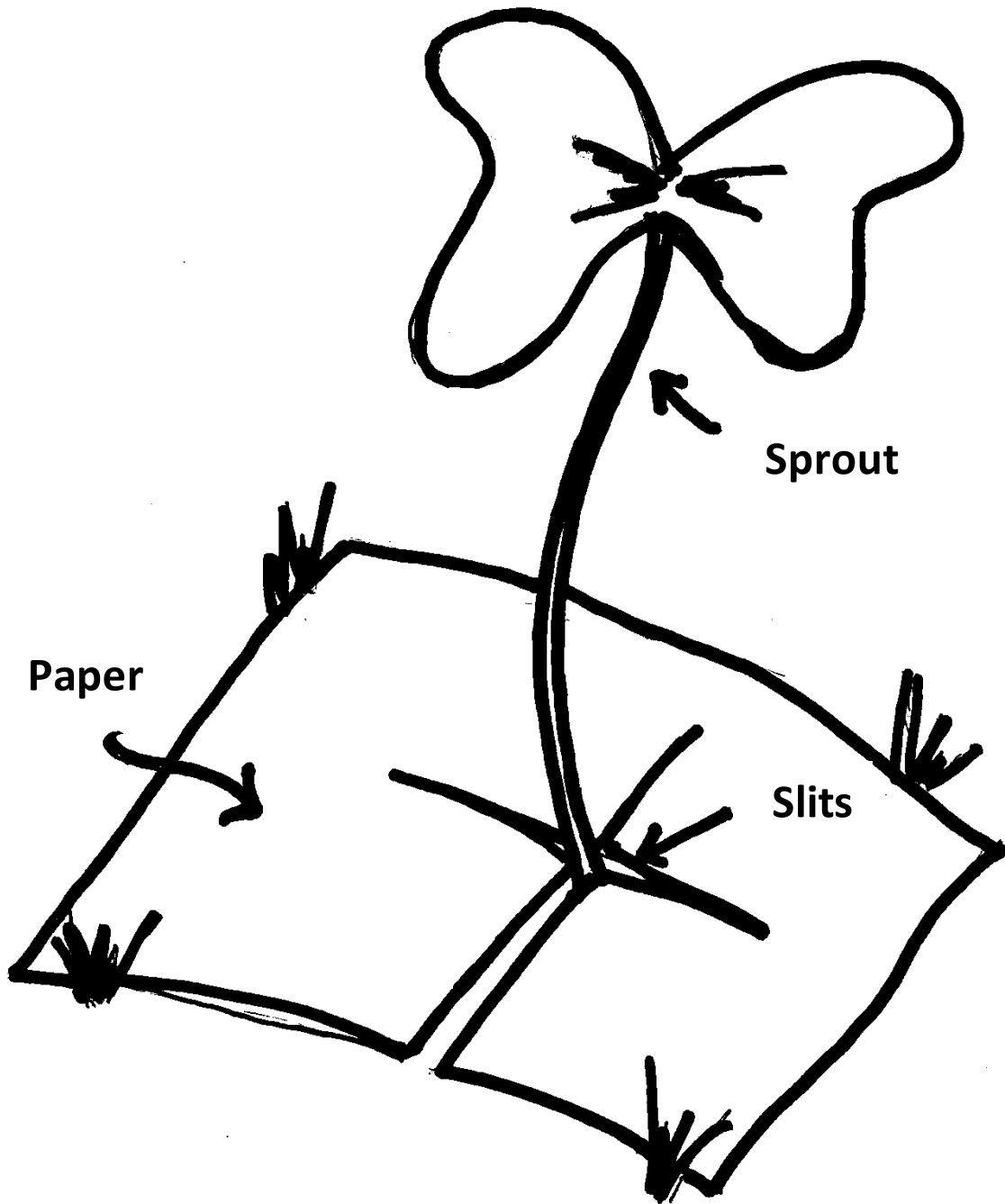

Lesson 8: Paper Barrier



Lesson 8: Non-Toxic, Homemade Remedies Cards

<p>All insect pests</p> 	<p>Crush 2 cloves garlic. Pour 1 litre boiling water over garlic. Cover and let it sit overnight. Strain liquid into a bottle. Spray the bottoms of the leaves daily, every few days or once a week.</p>
<p>Ants and Aphids</p> 	<p>Cut up orange peels into strips. Bury peels 3-5 centimetres in the soil OR Scatter peels around stems OR Hang peels from branches.</p>
<p>Soft-bodied insects (mites, aphids, mealybugs)</p> 	<p>Mix 1 spoonful of cooking oil and 2 spoons of soap into 1 litre of water. Shake well and pour into a spray bottle. Spray plant from above, <u>and</u> from below to get the underside of the leaves. Add more water to the mixture if the spray damages the leaves.</p>
<p>Mites and other insects</p> 	<p>Mix into a litre of water - two spoons of hot pepper sauce, OR cayenne pepper, OR ginger. Add a squirt of soap and mix well. Pour into a spray bottle and let stand overnight. Apply as above. Shake container frequently during application.</p>

Earwigs, slugs, and other soft-bodied garden pests

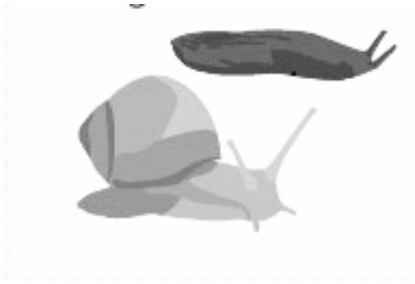

Put a little beer in a shallow container and place it in the garden. Slugs and snails crawl in but can't crawl out.

Fungal diseases



Mix three spoonfuls of baking soda into a litre of water.
Pour into a spray container and spray affected areas.
Repeat this process every few days until problem ceases.
Sprinkle cinnamon on seedlings affected by damp area fungus.

Eggshells

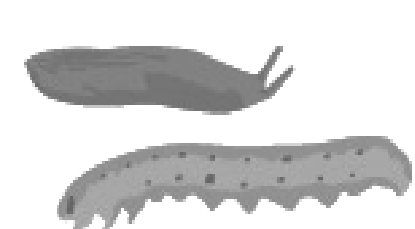

Crush eggshells.
Sprinkle them on top of the soil around the stems of plants.

Mildew



Mix equal amounts of water and milk.
Put in spray bottle and spray on tomatoes, cucumbers, lettuce, and other plants to control mildew.
Use the LABS concoction and spray on infected plants. Three treatments a week apart should control the disease.

Grubs



For lawn or garden grubs, use IMO2 and LABS from our concoctions list. These concoctions will feed the beneficial micro-organisms. These good micro-organisms will control the grub population. The grubs are actually the larvae of beetles. So, when you kill the grubs, you kill the beetle.

Old Latrine Pit or Hole

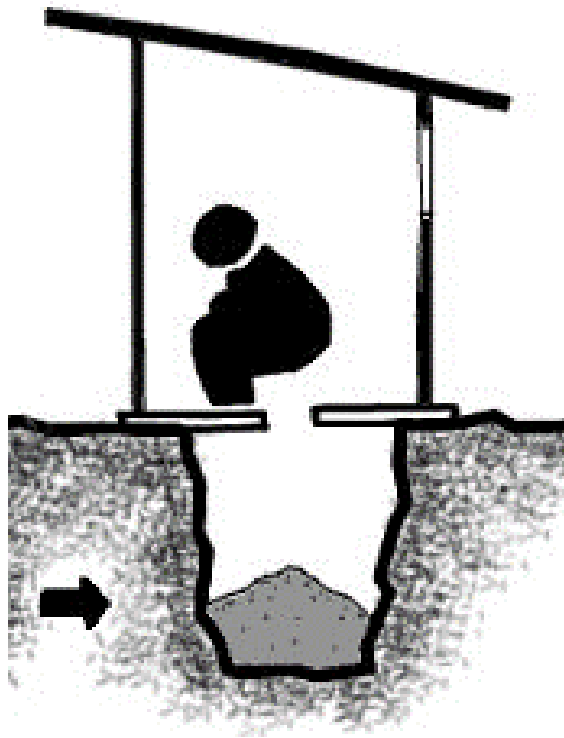

Cow Manure

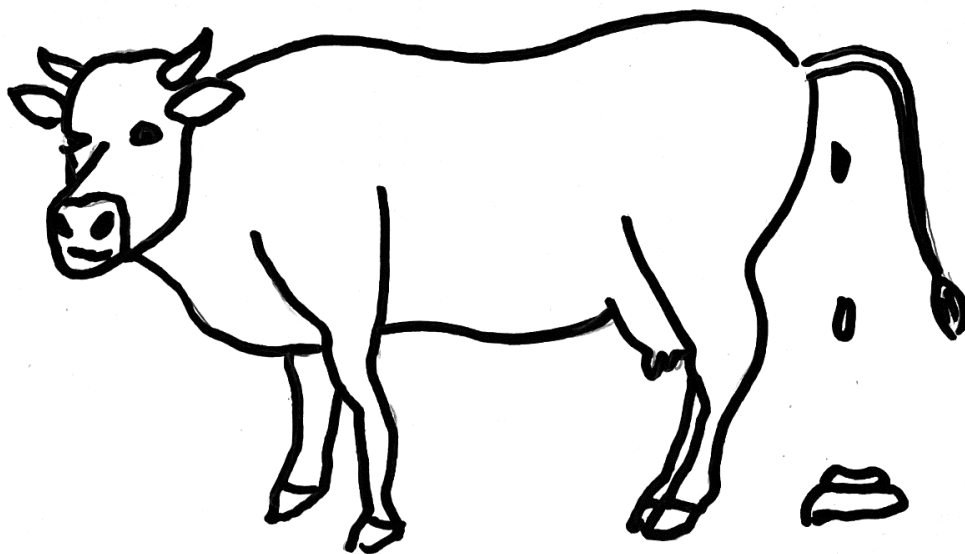

Dead Leaves



Old Straw from Animal Bedding

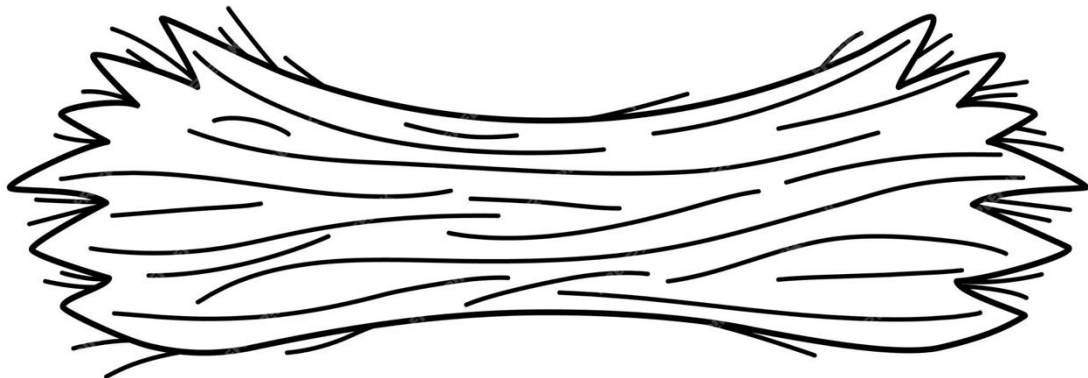

Dead Crop Residue



Weeds



Fire pit ashes



Lesson 10: Working Together to Glorify God

Learning More cards – Print one copy of each page – cut apart to make 10 cards

Controlling Pests

Improving Our Soil

Livestock care

Seed reproduction

Suppressing Weeds

Storage

Making Organic Fertilizers

Local Plant Diseases

(write your topic)

(write your topic)